

The 2nd Step



2010 Farm Member Handbook

One Step at a Time Gardens

Jan Libbey & Tim Landgraf

Phone: 641/495-6367, e-mail: libland@peconet.net

Address: 1465 120th St., Kanawha, IA 50447

web site: www.ostgardens.com

Our 2nd Step Member Handbook

TABLE OF CONTENTS:

2010 Season schedule information.....	Page 2
Delivery Details.....	Page 3
Welcome.....	Page 4
It's about the Food	Page 5
It's about Production.....	Page 6
It's about the People.....	Page 6-7
What if I...? <i>responses to common questions</i>	Page 8
Invitation and Directions to the Farm.....	Page 9
Final Comments.....	Page 10
Produce Calendar... an Excel Addendum	

Important 2010 Season Schedule Information

First Delivery – Des Moines and West Des Moines – Wed., June 2
North Iowa – Thursday, June 3

Special Every Other Week Share Note: EOW shares are set up to help balance the harvest demands on the farm. The following is the EOW delivery schedule for 2010.

- **EOW sites that begin on our FIRST week of delivery:** Kitchen Collage , Belmond, Farm, Garner, Clear Lake. These deliveries continue...every other week until Wed., September 22 for Kitchen Collage and Thur., Sept. 23 for all other sites listed here.
- **EOW sites that begin on our SECOND week of delivery:** West Des Moines , Clarion, Mason City. These deliveries continue...every other week until Wed., September 29 for West Des Moines and Thur., Sept. 30 for all other sites listed here.

The Delight is in the DELIVERY Details

Our cell for contact during delivery – 515/571-3383

WEDNESDAYS

Where

Downtown Des Moines

- Kitchen Collage, 430 E. Locust

-

West Des Moines

- St. Timothy's Church, 24th & Ashworth

When

4-5:30 p.m.

5-7:00 p.m.

Contact person

Teresa Tomka at 515/270-8202

Patty Dornacker at 515/314-0369 (cell)

THURSDAYS

Where

Clarion/ home delivery

Belmond/ 603 3rd St., NE

.

Farm/in farm cooler

Garner / 750 Cobblestone Dr.

Clear Lake/ 315 N. 4th St.

Mason City / 23 Oak Drive

When

2 - 5 p.m.

4:30-6:30 p.m.

3:00 – 8:00 p.m.

3:30 p.m.-5:00 p.m.

4:00 p.m. - 6:00 p.m.

4:30 – 7:00 p.m.

Contact person

Becky Ahrendsen at 515-851-1187

Sharion Hinman at 444 - 4291

Jan or Tim at 641/495-6367

Kathy Ingram at 641/923-5369

Murielle Hess at 641/357-7659

David& Laura Bernemann at 641/423-0817

Welcome to One Step at a Time Gardens!

We enter yet another season of providing wonderfully fresh and delicious food straight from our farm. This handbook will introduce you, our farm members, further to the farm member experience. We will be the source of much of your fresh produce this season. This handbook is full of information that will help you all season long. Look over our Table of Contents and you will find a thorough introduction to who we are and how we operate; meet our farm family and our summer crew, delivery details are handy on page 3 and there's a map to the farm on page 8 to help you find your way here for a visit!

We want you to have information about the food, the farm and people working at the farm. We hope this resource will help you to make the most of the fresh food from our farm this season.

Food for thought:

On the one hand, a trip to the grocery store has practically become a geography lesson with food we eat coming from Florida, Central and South America and even Asia. According to the Leopold Center for Sustainable Agriculture, more than 80% of the fresh fruits and vegetables we consume in Iowa are shipped into our state, traveling an average of 1,500 miles. The out of sight, out of mind production fosters an attitude of disconnection that is impacting the public's health and that of the whole system that feeds us. On the other hand, news stories, research and anecdotal experiences continue to reveal that there is growing demand for food that contributes to our whole health; food with integrity: food that people do have a greater connection with. There's a resurgence of longing for a stronger food connection underway.

Our farm's membership program is one of the responses to that growing demand for "food with a face". We're excited to be part of the emerging local food landscape in Iowa. What makes it possible is that people just like you are stepping in to help support an agriculture that grows food with connection. We are a community-based farm and we wouldn't be here without you. Your food choice is a powerful act. We invite you to explore the flavors and stories of local food as you eat your way through the season with us. We will offer news and insights into the workings of this farm as well as Iowa's local food activity.

We hope you will enjoy every bite of this summer. But we encourage you to expect more from us than just our high quality vegetables. We want your farm membership to help reconnect you to the experience, patterns and places of great food. We see this as a partnership of agriculture that supports the community and grows the community that supports agriculture. Please do not hesitate to contact us with any comments, questions or concerns. We want to help you make the most of your membership.

~ Jan & Tim

It's about the food

Fresh, quality food - Quality and cleanliness are priorities at One Step at a Time Gardens. We are local, and select varieties for flavor rather than transportation endurance. We start most of our own plants and bring you varieties not available through commercial outlets. We harvest the day before and the day of delivery. We wash and keep produce in a cooler prior to delivery. Please refrigerate your produce as soon as possible to retain its freshness and nutrients.

Packaging - We use waxed, cardboard boxes to deliver your vegetables. We try to minimize use of plastic bags where possible, providing items in bulk in the box when we can. We can't reuse your plastic bags, but we do count on reusing your box.



Each week we exchange boxes - you return an empty box in exchange for a full one. We get repeated use of these boxes so please help take care of them. We ask you to flatten your box for the return. A handout to explain box unfolding techniques - Box Care 101 - will come in your first delivery.

Communication – We want to encourage good communication. For each week's box we write a "Weekly Note" featuring a list of that week's produce, update on farm activities, and other information. You can't miss the note - we will email it out on Tuesdays to give you a sneak preview of the week's delivery, will have hard copies available at each delivery site and it will be posted on our website. We're also available in person at most delivery sites and always just a phone call or email away. Don't hesitate to contact us.

Eat Seasonally ...the farm member learning curve

Eating seasonally can take some time to get used to. Weekly deliveries move you through the season, bringing subtle, yet detectable changes in how we relate to our food and the land. Taste the changes through the season. We invite you now, as you are anticipating your summer's supply of vegetables to begin to think about what eating seasonally means. Check out the Produce Calendar, provided as an Excel addendum to this handbook for an overview of what will be coming when.

Pay attention to your own reaction as the vegetables shift throughout the season. We will start with cool-season lovers like green onions, greens, radishes, edible peas, broccoli, and more. The warmer season crops such as zucchinis, tomatoes, onions, etc. come on in July and August. By the last couple weeks of deliveries in September, we'll begin to see "comfort" foods such as winter squashes appear. Whether you want to become a "purist" about eating seasonally or not, a farm membership offers to reconnect you to the subtle ebb and flow of seasonal energy as manifest through the garden harvests.

Three "Timely" Tips

Take & make time with your food

1. *Plan for the time needed* to work and cook with fresh ingredients.
2. *Good tools help* - A salad spinner, a vegetable grater or food processor, and a sharp knife help time efficiency in the kitchen.
3. *The ingredients in a meal are only part of the experience.* Take time to savor mealtime with family and friends. Good food savored in good company is one of life's great treats!

It's about the production practices...Four Primary Practices

Healthy plants begin with healthy soils.

We manage our farm through natural production methods, including crop rotation, compost, cover crops, and biological, organically-approved treatments. Diverse plantings throughout the farm encourage beneficial insects. We DO NOT use any synthetic herbicides or pesticides

Getting the work done: Working smart

Our farming relies heavily on careful planning, attention to detail during the growing season, skilled use of tractor implements, some unique small-scale tools, and hand labor.

Our chickens - two-legged fertilizers.

Each year, several of our garden plots are dedicated to our “chicken tractors”.

Mobile pens help the broilers we raise do their part as soil nutrient applicators while providing them with predator and weather protection. The following year, these chicken plots are turned back to vegetable production.

The Farm as Natural Habitat

Our farming is built around ecological principles; from diverse natural features to emphasis on seasonal rhythms. The results are in the quality of our products, the spirit of those who work with us and buy from us, and the creatures that share this land with us .

It's about the people - Meet Your Farmers

Our whole family is involved in our farm operation. Tim, Jan, Andrew, and Jess each bring our unique perspective and skills and play distinct roles. Read about each of us below. We are committed to producing high quality, naturally raised vegetables for our farm members. We are active in Iowa's sustainable agriculture community as well as our local community. We have used this work to meet our goals of supporting each other and creating a unique experience that blends work and life choices together.

Tim...is the detail person. He plans production systems such as our crop rotation, our produce wash station, and all of our record keeping and analysis. Tim currently serves as President of the Board of Directors of Practical Farmers of Iowa (PFI) and several Advisory Boards related to PFI projects.

Jan ... is the people person. She's often the “face” and voice of our farm, speaking about the farm and local food with farm members, working closely with our summer crew, selling at and assisting local farmers market development.

Andrew, 21 - Living and working in Lincoln, NE this summer, continues as our webmaster. His passion for website design is reflected in the farm website which he manages for us. In August, he will head back to the University of Nebraska at Lincoln for his Senior year in Ag. Engineering.

Jess, 18 – Will be working at a camp this summer getting her regular dose of outdoors, but not with all the farm chores she has previously assumed. Then in late August, Jess will head to beautiful Decorah for her freshman year at Luther College.

Our family wouldn't be complete without note of these two friends –

Lion - At 14 years, he still always ready to greet you



runs like a young dog, but increasingly enjoys naps in the sun. He is with his characteristic head waggle and happy grin.

Sass - You can find her enjoying a pasture full of grass, her white blaze visible when you stop by for a visit, don't miss saying "Hi" to her, she'll gladly greet



from the road. And you with a whinny!

Meet the Summer Crew 2010

Becky Ahrendsen, of Clarion – is one of our founding farm members and helps with Clarion deliveries and farm work starting early spring through fall wrap-up. She always brings delightful energy to the farm!

Christa Hanson and her children Christa, Anna, Matthew, Luke and Kaleb, of Kanawha – This family team brings enthusiasm and energy to the farm. "The whole team is involved with early season field work. Young Christa and Anna will continue through much of the season. Helping at the farm fits in with the home-school lessons Christa and her husband, Mark, coordinate for their children.

Luke, Levi, & Liz Leckrone, of Kanawha – These siblings live across East Twin Lake from the farm and sometimes hike through the woods on their way home. Luke and Levi bring a great work ethic along with a penchant for jest, keeping the work time lively. This will be Liz's first summer putting in more hours at the farm and we look forward to having her here.

Brian McGurk- A Social Science teacher and coach at Clarion- Goldfield School District, Brian will be helping once again during his summer break. Brian's enthusiasm for life is expressed not only in all his work with students, but also through his growing repertoire of roles in the local community theatre productions.

Our summer interns work and live at the farm, experiencing a rich mix of hands-on exploration of community-based agriculture and head discussion about sustainable agriculture developments and the local food networking in Iowa.

Our 2010 interns include...

Genesis & Eli – This couple is coming to us from Portland, OR where they've been working and living for the past several years.

Genesis, with a degree in ... from Lewis & Clark College, has been employed through Americorp in various team leader roles.

Eli, with a gift for .. has been working as a tile layer.

These two are taking the brave step of leaving known work to step into a summer of farming. "It's something we've wanted to do for a long time," said Genesis, "and now just seems the right time to take that step."

What about all of **our Farm Members?**...

Farm Members - We couldn't and wouldn't do this without you!! Members help in many ways serving as sounding boards when we have planning issues, helping recruit new members, lending support during trying times at the farm, coming to visit the farm, and serving as site hosts to name a few. If you want to get more involved, just let us know. Members are welcome to come spend a day with us and experience the farm from the inside! Give us a call.

What if I...?

Here is a list of responses to common questions.

...miss my box pick up time?

Each site contact has a slightly different approach to handling missed boxes, but all are very conscientious and will make every effort to accommodate reasonable delays. We provide a contact name and phone number for each delivery site (Page 3) in addition to our own contact. Out of courtesy to our site hosts, please contact them ASAP if you can't get to a pick up. You can almost always determine an alternative pick up arrangement.

NOTE: We can not guarantee condition of box contents after pick up hours.

We do have a policy that boxes left unclaimed after 24 hours are fair game for site hosts.

...go on vacation or am out of town on a delivery day?

If you can't meet a week's delivery and you know well ahead of time, we ask you to have a friend try your box - this makes a nice gift - or simply request that we do not pack one for you .

We do not adjust Every Other Week deliveries to a subsequent week.

Please give us at least 1 week's notice of any changes.

Emergency situations will be handled separately.

...need to switch delivery sites

We really discourage this after the start of deliveries because of the disruption it creates to our delivery organization. Please do not ask us to switch your delivery site once the season gets underway.

...forget to return my box?

We do ask members to return an empty box each week. This has proven a challenge for Every Other Week shares due to the intervening week. If you find boxes become a real challenge to keep track of, we recommend you bring a sack to the delivery site. With a string bag or sack for your veggies, you can simply empty your box contents directly into your sack and leave the now empty box at the delivery site. Please return your box regularly.

...have a problem keeping up with the supply? Or get items I don't like?

There is a learning curve with receiving your ingredients before deciding your menu as you do with this program. We encourage you to be patient with yourself and this program. You will receive a copy of our Recipe Collection as an additional resource and we encourage you to purchase the Asparagus to Zucchini Foodbook. Talk with other members at pick up too – other members often have ideas to share. That's the beauty of the *community* in Community Supported Agriculture.

...find mid-way in the season this program just isn't working for me?

We will address any such situation on an individual basis to arrive at a mutually agreeable resolution.

Please do contact us with any comments, questions, or concerns!

We can be reached at libland@peconet.net or 641/495-6367

Visit the Farm

We invite you to consider this your “adopted” farm. Not only will this be your source of weekly vegetables throughout the season, it is also a beautiful location to visit. Nestled in among the rolling, glacial hills of North Central Iowa, we invite you to make the farm one of your summer outings! Come tour the gardens, dip your canoe or kayak in East or West Twin Lake, hike East Twin Lake woods in search of the heron rookery or fresh raspberries, take a hike on our trail to the “Big Hill” with its view of the wetland on the farm, or plan a picnic with our work crew! Our website features scenes from the farm throughout the year, but there’s nothing quite like a first hand visit. You are always welcome. Please call ahead to make arrangements.

Sunday, August 8, 2010 , 2 – 5 p.m. – Farm Anniversary Celebration –

Mark your calendars now! This season we mark 15 years of great food from this farm to our members and market customers. A special celebration will involve time to enjoy the farm and it’s story to the fullest - whether you just want to sit back and enjoy a delightful afternoon in the summer breeze or jump into a scavenger hunt and the stories that that hunt leads to. Great food is a guarantee with our potluck and some great tunes by the Porch Stompers will top off the event. Watch for more details this summer.

Directions to the farm:

To get to : 1465 120th St., Kanawha

From Mason City: Hwy 18 West to Garner, South on Hwy 69 to B55/Klemme intersection. Go west on B55 for three miles and then south on R56 for five miles. Turn west on 120th St. (gravel) for 1.25 miles.

From Des Moines: I-35 north to D20, West on D20 to Hwy 69. Go north on Hwy 69 to the junction with Hwy 3. Turn east on Hwy3/69 and continue north on Hwy 69 through Belmont and on up to Goodell. Turn west on B63 at Goodell for three miles. Turn north on R56 for one mile. Turn west on 120th St. (gravel) for 1.25 miles.

~ Plan some *farm* into your summer ~

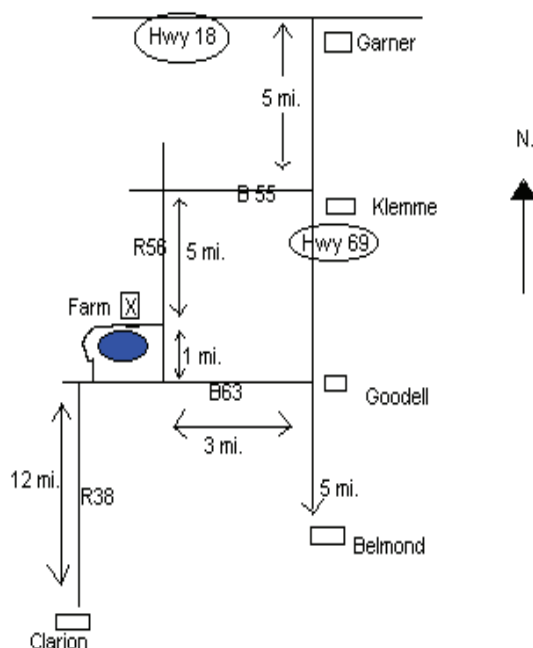

A Final Comment

We are committed to raising healthy food... ..raising hope

Our commitment to you and the environment is to provide fresh, clean, sustainably grown vegetables throughout the season.

The purchase of your food is a simple, but very powerful choice. With every bite you take of food grown by our farm, you are making a significant difference. You are eating fresh, in-season produce, broadening the diversity of food in your diet, and supporting food grown without synthetic chemicals or pesticides. You are also investing in community-based agriculture - where farmers and eaters work together to create a new food system.

Food: a simple choice, a powerful choice.

Thank you for your membership!

~ Jan & Tim